

---

---

# Part Replacement Instruction

---

---

**Product:** SUPERSTAR 4

**Parts Replaced:** Motor Control Board and CPU Board

**Required Tools:**

#1 Phillips Screw Driver  
#2 Phillips Screw Driver  
Small Slotted Screw Driver  
3/8 Open End Wrench  
Anti-Static Wrist Strap

## Procedure:

NOTE: This procedure involves a great many steps to complete. We recommend that you read through the entire procedure before beginning.

Physical Replacement:

1. Turn the machine off and unplug the Power Cord from the wall socket and the rear of the machine (See Figure 1).

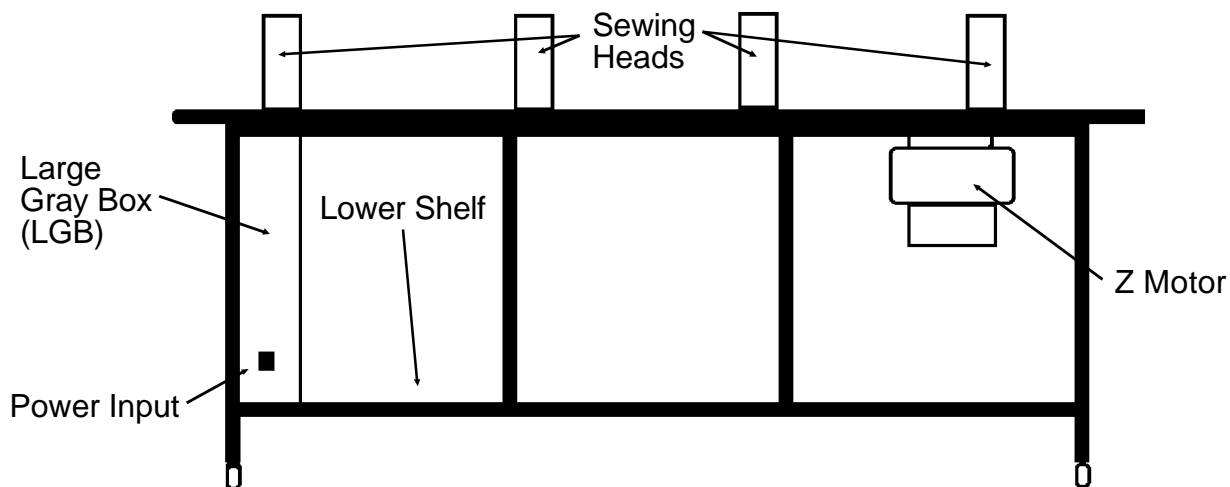

Figure 1 - Rear View

2. Put on the Anti-Static Wrist Strap and attach the free end to a non-painted metal area of the machine.

NOTE: In order to remove the rear-most Connector in the next step, you will need to loosen the two Connector Retaining Screws located on the sides of the Connector.

3. Unplug the five Connectors (Figure 2-A) from the top of the Large Gray Box (LGB), located on the left end of the machine, as viewed from the rear. (See Figure 1) Remember the location and orientation of each plug as it is disconnected.

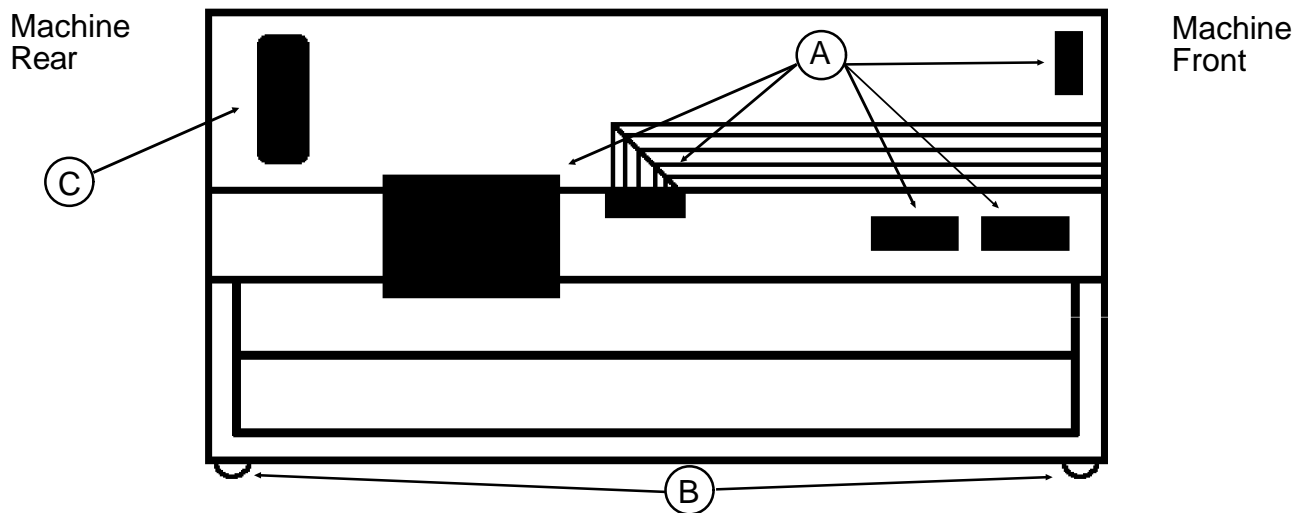

Figure 2 - Top View of LGB

4. Remove the four retaining screws (Figure 2-B) holding the Fan Panel to the interior side of the LGB and lay the Fan Panel on the lower shelf.

## Removing the Motor Control Board:

5. Disconnect the twelve pin Connector (Figure 3-E) from the Motor Control Board (Figure 3-D).

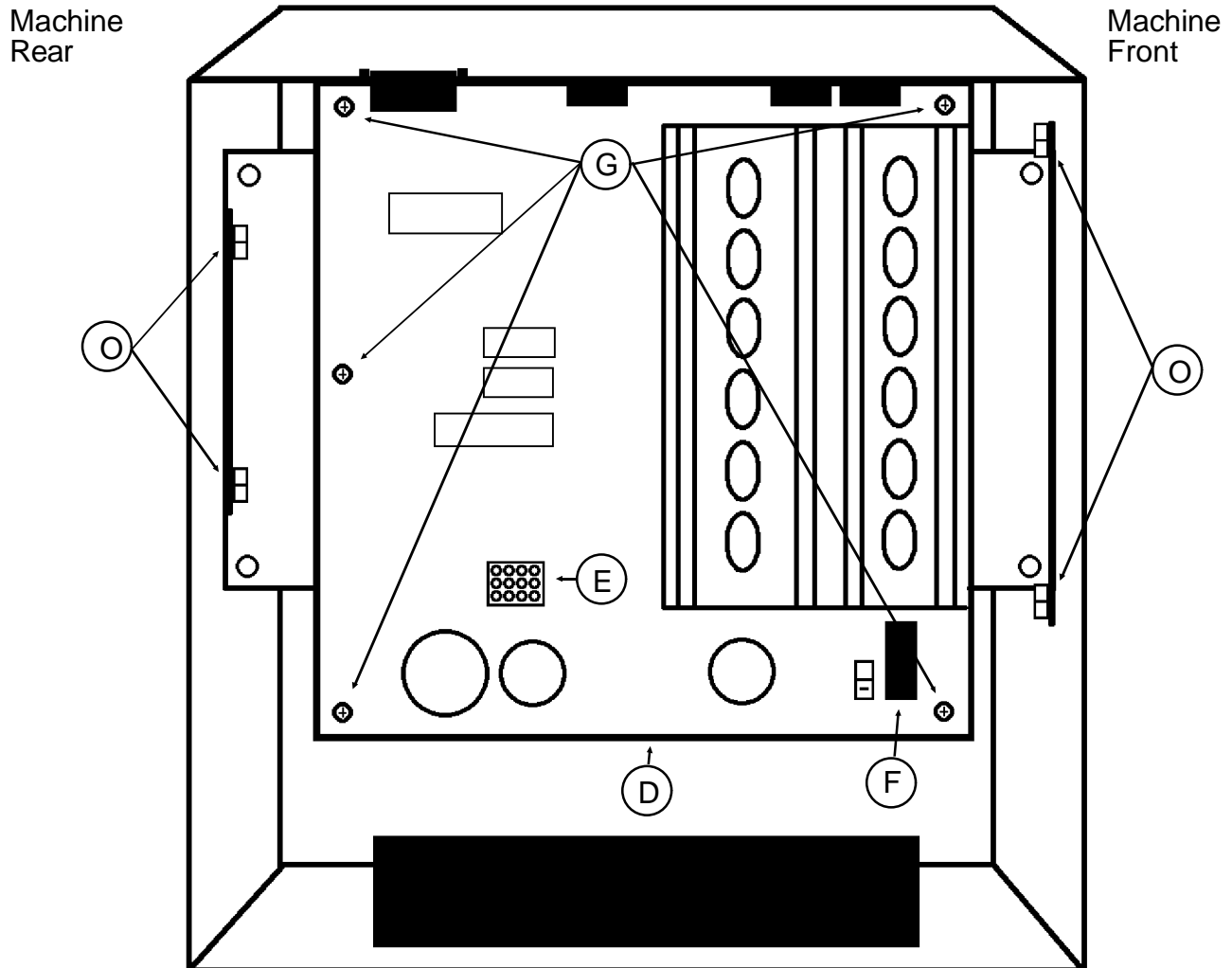

Figure 3 - LGB with Fan Panel Removed

6. Loosen the two Connector Retaining Screws on the side of the black "T" Connector (Figure 3-F) and unplug the Connector from the Motor Control Board.
7. Loosen the five Retaining Screws (Figure 3-G) holding the Motor Control Board to the Board Mount.
8. Grasp the Motor Control Board by the black metal fins on the right side of the board and pull the Board away from the mount.

NOTE: If you are only replacing the Motor Control Board, go to step 33.

## Removing the CPU:

- Remove the four retaining screws holding the outer cover of the LGB to the frame of the machine and remove the cover, exposing the CPU Board (Figure 4-H).

Machine  
FrontMachine  
Rear

Figure 4 - LGB with Outer Cover Removed

- Disconnect the small blue Ribbon Cable from the lower left Connector (Figure 4-I).
- Disconnect the large blue Ribbon Cable from the upper right Connector (Figure 4-J).
- Carefully pull the two Cables disconnected in steps 10 and 11 through the hole in the top rear of the LGB (Figure 2-C). You will find this task easier if you pull one Cable at a time.

13. Disconnect the six pin Connector (Figure 4-K) from the lower left of the corner of the CPU.
14. Disconnect the blue Ribbon Cable from the lower right corner Connector (Figure 4-L).
15. Remove the Program Board from its slot (Figure 4-M) and lay it aside on a clean, static free surface.
16. Remove the Alphabet Boards from their slots (Figure 4-N) and lay them aside on a clean, static free surface.
17. Loosen the four interior Retaining Nuts (Figure 3-O) holding the Motor Control Board/CPU Mounting Plate in the LGB.
18. Remove the Mounting Plate from the interior of the LGB by rotating the right edge toward you and the left edge away from you. When the Mounting plate comes free of all four mounting posts, pull the entire Mounting Plate out of the LGB.
19. Loosen the two Connector Retaining Screws on the side of the black "T" Connector (Figure 4-P) and unplug the Connector from the CPU.
20. Remove the four retaining screws (Figure 4-Q) holding the Alphabet Cage (Figure 4-R) to the CPU and remove the Cage.
21. Remove the four retaining screws (Figure 4-S) holding the CPU to the Mounting Plate.
22. Remove the CPU from the Mounting Plate.

#### Installing the CPU:

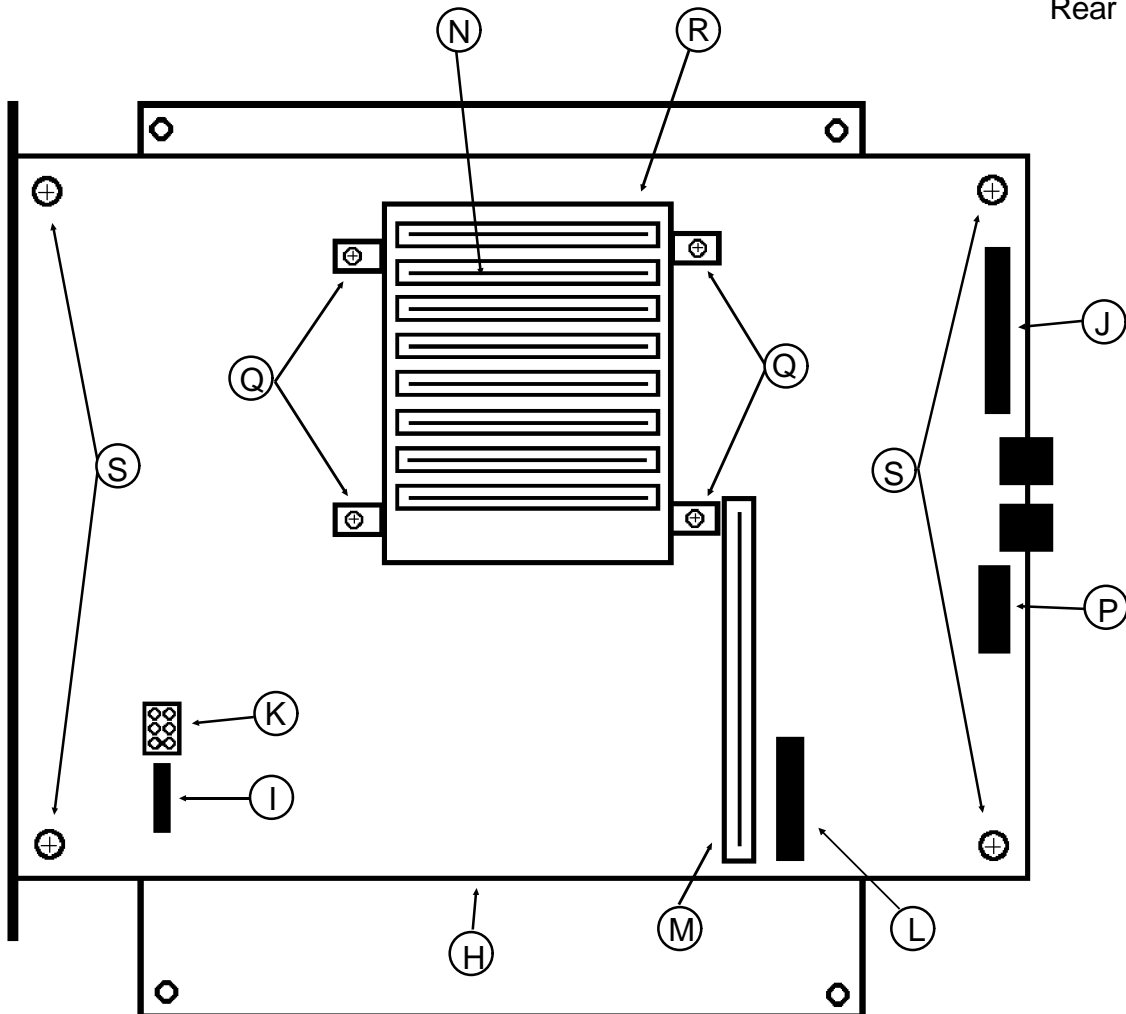
23. Install the new CPU onto the Mounting Plate and secure it with the four screws removed in step 22.
24. Place the Alphabet Cage in place on the CPU Board and secure it with the four screws removed in step 21.
25. Plug the "T" Connector into its receptacle and secure it with the two retaining screws on the side.
26. Install the Mounting Plate into the LGB. Slide the Plate, rear edge first, into the LGB, then rotate it into place so that the slots on the edges engage with their posts.
27. Tighten the four Retaining Nuts loosened in step 17.
28. Install the Alphabet Boards removed in step 16 into their slots.
29. Install the Program Board removed in step 15 in its slot.
30. Plug the blue Ribbon Connector into its Jack on the lower right corner of the CPU.

31. Feed the two blue Ribbon Connectors removed in step 12 into the interior of the LGB and plug them into their Jacks.
32. Replace the outer cover of the LGB to the frame using the four screws removed in step 9.

Installing the Motor Control Board:

33. Position the Motor Control Board in place and secure with the five Retaining Screws in the Board.
34. Plug the "T" Connector into its receptacle and secure it with the two retaining screws on the side.
35. Plug the twelve pin Connector into its receptacle.
36. Replace the Fan Panel to the LGB with the four retaining screws removed in step 4.
37. Plug the five Connectors removed in step 3 into their proper receptacles.

NOTE: Remember to secure the rear-most Connector with the two Retaining Screws on the side of the Connector.

Calibration:

38. Plug the Power Cable into the wall socket and the rear of the machine, and turn the machine on.
39. After the "Power Up" test is successfully completed, enter the following keystroke sequence on the Keyboard:
  - A. Depress the [SHIFT], [CTRL], and [RSET] keys, in that order.
  - B. Depress the [CAPS] key to turn off the CAPS Light.
  - C. Type "cal".
40. The Z Axis Motor will begin to run slowly and the Keyboard will begin to beep continuous until the self-calibration cycle has completed.
  - A. After a few seconds, the Motor will stop running for about five seconds.
  - B. The Motor will begin to run at fast speed for a few seconds, then stop again.
  - C. Within five seconds, the Motor will again start running at fast speed, then begin to reduce its speed in noticeable increments every few moments until the Motor stops. This will take between one and three minutes. When the Motor stops turning, the Keyboard will stop beeping and the calibration is complete.

NOTE: If the sequence of events explained in steps 39 and 40 do not occur, you may have other problems in the system. Contact the Melco Technical Services Section for further assistance.