

---

---

# Part Replacement Instruction

---

---

**Product:** SUPERSTAR 4 and EMC 6/4

**Part Replaced:** Color Change Board

**Required Tools:**

3/32 Allen Wrench  
5/54 Allen Wrench  
Slotted Screw Driver  
Anti-Static Wrist Strap

**Procedure:**

1. Turn the machine off and unplug the Power Cord from the wall socket.

NOTE: You may find it easier to perform the following steps if you unthread your machine before beginning.

2. Put on the Anti-Static Wrist Strap and attach the free end to a non-coated metal area of the machine.

NOTE: Be sure to hold on to the Tensioner Assembly during the next 3 steps.

3. Remove the two retaining screws (Figure 1-A) holding the Tensioner Assembly (Figure 1-B) to the Color Change Cover (Figure 1-C).

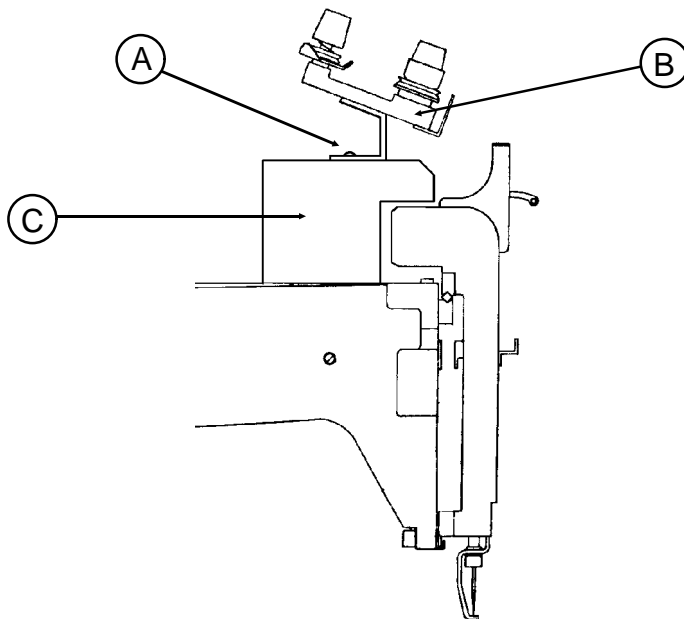

Figure 1

- Slightly lift the Tensioner Assembly and Color Change Cover. Locate where the Tensioner Cable Plugs into the Color Change Board (Figure 2-D) at J2904 (Figure 2-E).

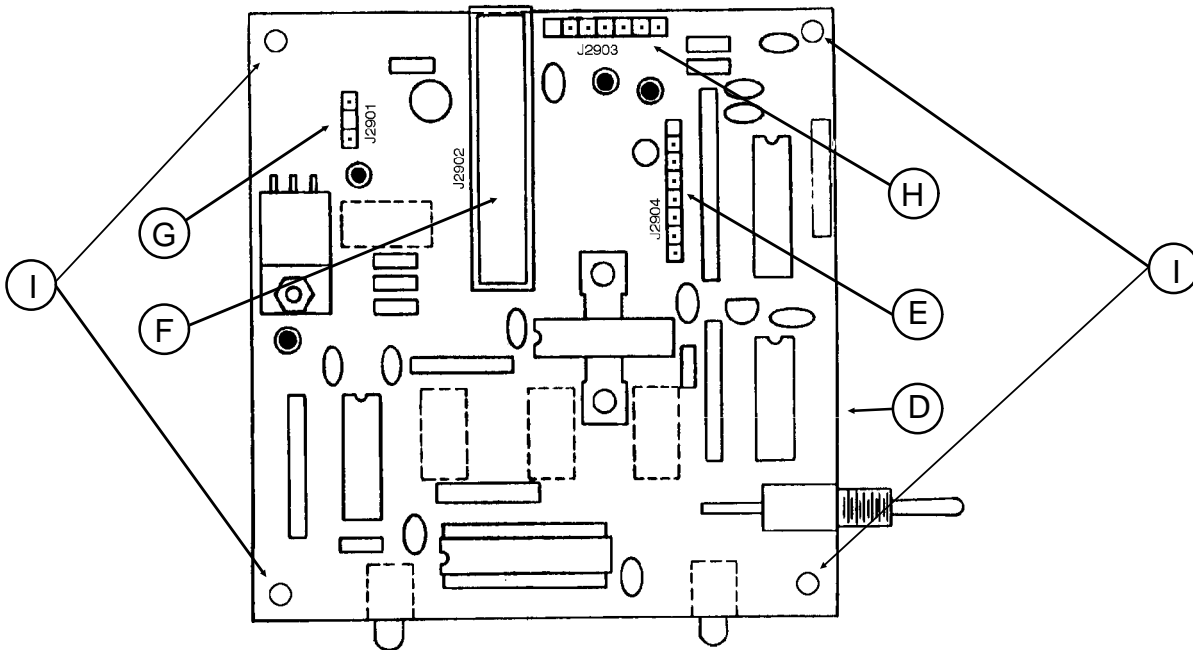

Figure 2

- Carefully unplug the Tensioner Cable from the Color Change Board and lay the Tensioner Assembly and Color Change Cover aside.

NOTE: The physical appearance of the Color Change Board may vary somewhat from Figure 2, however the applicable connectors will still be in the correct location.

- Unplug the Main Power Cable from J2902 (Figure 2-F).
- Unplug the Jump Stitch Cable from J2901 (Figure 2-G).
- Unplug the Color Change Motor Cable (if present) from J2903 (Figure 2-H).
- Locate the four white Mounting Tabs (figure 2-I) holding the Color Change Board in place. Press the center lock of each Tab in to release the Board, and lift up on the edge of the Board.
- Carefully lift the Color Change Board off of the machine.
- Install the new Color Change Board on the Mounting Tabs.

NOTE: Make sure that the Color Change Board snaps securely onto the Mounting Tabs.

- Plug the Color Change Motor Cable (if present) into J2903.

13. Plug the Jump Stitch Cable into J2901.
14. Plug the Main Power Cable into J2902.
15. Position the Color Change Cover and Tensioner Assembly over the Color Change Board and plug the Tensioner Cable into J2904.
16. Place the Color Change Cover and Tensioner Assembly in their correct seating location and secure them with the retaining screws removed in step 3.
17. Remove and disconnect the Anti-Static Wrist Strap.
18. Re-thread the machine and perform a test sew out.

END OF PROCEDURE